

Manual Oil Pumps



Manual pump for oil. The telescopic suction tube enables direct application on containers of different capacities. Suitable for delivering low/high-viscosity oil.



Viton Seals

NBR Seals

Package Part No.	P/N 31200-55	P/N 30200-55-55
Suitable for drums	60 Liter to 205 Liter	
Length delivery hose	7'	7'
Quantity delivered with complete cycle of lever	0.5 lb	0.45 lb
Max. density oil deliverable	SAE 130	SAE 240

Single-action occurs when the pumping piston delivers the fluid only in the pumping lever downstroke



Double-action occurs when the pumping piston delivers the fluid in its upstroke and downstroke. Double-action delivers the fluid with a continuous and constant flow

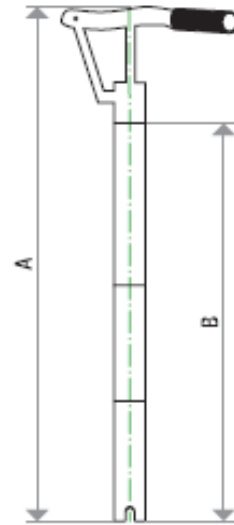
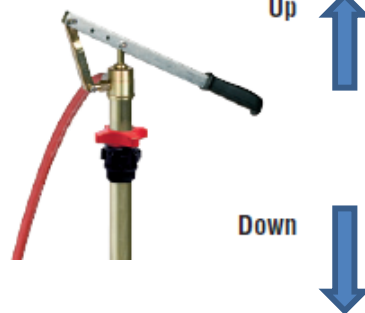

Part No.	A	B
31200-55	33.8" - 47.2"	27.5" - 40.9"
30200-55	33.8" - 47.2"	27.5" - 40.9"



Double-acting manual pump for oil and NBR seals. The telescopic suction tube enables direct application on containers of different capacities. Suitable for delivering low/high-viscosity oil.



For 60 Liter Keg

24 Liter Capacity

Package Part No.	P/N 30201-55	P/N 30202-55	P/N 32024-55
	Double-acting manual pump for drums 60 Liter complete with drum cover ϕ 17" for drum application and digital electronic counter	Double-acting manual pump for drums 60 Liter complete with fixing ring for drum application and drum cover ϕ 17"	Manual oil dispenser with wheel-mounted 24 Liter tank, equipped with:- level gauge- P/N 24891-55 antisplash funnel
Suitable for drums	60 Liter	60 Liter	24 Liter Capacity
Length delivery hose	7'	7'	7'
Quantity delivered with complete cycle of lever	0.45 lb	0.45 lb	0.45 lb
Max. density oil deliverable	SAE 240	SAE 240	SAE 240

Hooking	Pumping shaft stroke	Compression ratio	Delivery capacity with complete cycle	Oil viscosity
3	5"	1:2.2	0.5 lb	SAE W 80/90
2	4"	1:3.6	0.4 lb	SAE W 85/140
1	2"	1:6.9	0.2 lb	SAE 240

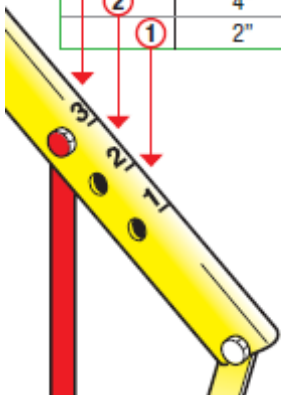

Note: The position of lever pivot can be varied (3 hookings) to adapt the pumping force to the viscosity of the oil used.

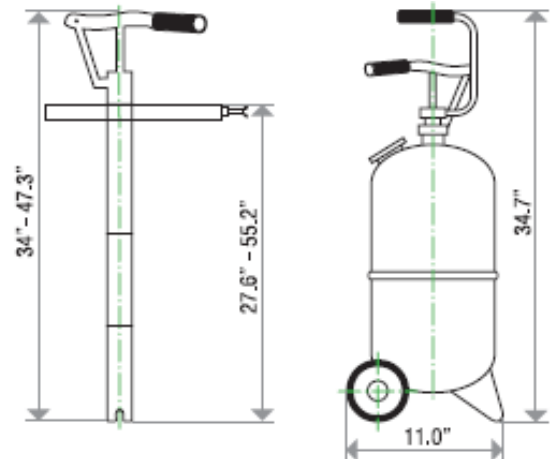

P/N 30201-55 30202-55

P/N 32024-55

PRO/MARK INDUSTRIALS
Div. R.D. Lewis Sales Limited
Manufacturer's Representative

Double-acting manual pump for oil and NBR seals. The telescopic suction tube enables direct application on containers of different capacities. Suitable for delivering low/high-viscosity oil.



For 20 Liter Pail

For 20 Liter Pail

Package Part No.	P/N 30206-55	P/N 30207-55
	Double-acting manual pump for drums 20 Liter pail complete with drum cover ϕ 12" for pail application and digital electronic counter	Double-acting manual pump for drums 20 Liter pail complete with drum cover ϕ 12" for pail application – no meter.
Digital Meter	32713-55	None
Suitable for pails	20 Liter	20 Liter
Length delivery hose	7'	7'
Quantity delivered with complete cycle of lever	0.45 lb	0.45 lb
Max. density oil deliverable	SAE 240	SAE 240



P/N 32713-55
Digital meter with adaptors suitable for manual pump or air operated oil dispenser

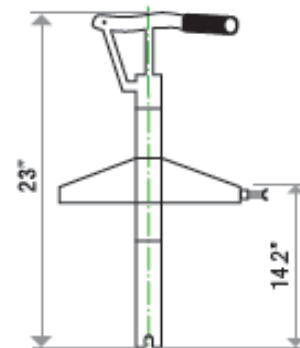

PRO/MARK INDUSTRIALS
Div. R.D. Lewis Sales Limited
Manufacturer's Representative